

Table of Contents

1. Introduction, Features and Applications	2
2. Specifications and Operating Environment	3
3. Driver Connectors P1 and P2	4
4. Control Signal Connector (P1) Interface	5
5. Driver Connection to Motors (P2)	6
6. Power Supply and Driver Voltage and Current	9
7. Selecting Microstep Resolution and Driver Current Output	11
8. Protection Functions	12
9. Connection Diagram for Driver, Motor, Controller	13
10. Control Signal Waveform and Timing	13
11. Wire Connection	14
Appendix: Limited Warranty	15

1. Introduction, Features and Applications

25078 are high performance microstepping drivers incorporating the most advanced technology in the world today. They are suitable for driving any 2-phase and 4-phase hybrid step motors (current 7.8A/3.9A). By using advanced bipolar constant-current chopping technique, they can produce more motor torque at high speed than other drivers. The microstep capability allows stepping motors run at higher smoothness, less vibration and lower noise. The 3-state current control feature leads to lower motor heating.

Features of this driver

- High quality, low price
- Low heating for motor & driver
- Supply voltage AC80-250V
- TTL compatible inputs
- Automatic idle-current reduction
- Output current up to 7.8A peak (RMS 5.57A)
- Input frequency up to 400KHz
- Opto-isolated inputs
- Microstep resolution pulse per rotation selectable vary from 400, 500, 600, 800, 1000, 1200, 1600, 2000, 2400, 3200, 4000, 5000, 6000, 6400, 8000 and 10000
- Suitable for any 2-phase stepping motor with 4,6,8 leads
- DIP switch current setting
- CW/CCW mode available

Applications of this driver

Applicable for automated machinery and equipment, for instance, air-driven inscription machines, labeling machines, cutting machines, laser engraving, plotter, medical instruments, and pick-place devices.

2. Specifications and Operating Environment

Electric Specifications ($T_i = 25^\circ\text{C}$)

Parameters	25078			Unit
	Min.	Typical	Max.	
Output Current	0.42 (RMS0.3A)	-	7.8	Amps
Supply voltage (DC)	80	180	250	VAC
Logic signal current	7	10	16	mA
Pulse input frequency	0	-	400	Khz
Isolation resistance	500			MΩ

Operating Environment and Parameters

Cooling	Natural cooling or forced convection	
Environment	Space	Avoid dust, oil frost and corrosive gas
	Temperature	0° - 50
	Humidity	40 - 90%RH
	Vibration	5.9m/s ² Max
Storage Temp.	-20 - 125	
Weight	Approx. 1.16 kg (41 oz)	

Mechanical Dimensions (unit:mm, 1 inch = 25.4 mm)

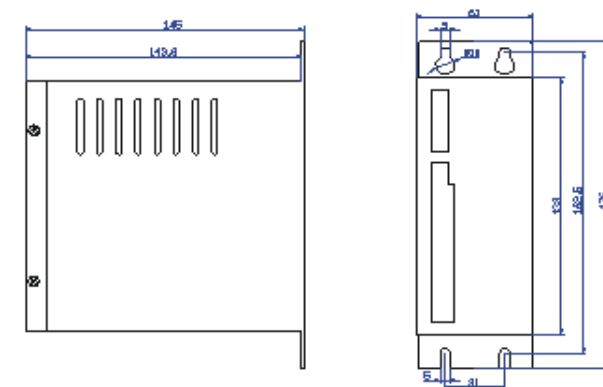

Front View

Side View

Figure 1: Mechanical dimensions

*Recommended to use side mounting for better heat dissipation

Extra Heat Sink

- Driver's reliable working temperature should be $<65^{\circ}\text{C}$, motor temperature $<80^{\circ}\text{C}$;
- It is recommended automatic half-current mode, i.e. current automatically reduced by 60% when motor stops, so as to decrease driver and motor's heating;
- Please mount the driver vertically to maximize heat sink area.

3. Driver Connectors, P1 and P2

The driver has two connectors, P1 for control signals, and P2 for power and motor connections.

The following is a brief description of the two connectors of the driver. More detailed descriptions of the pins and related issues are presented in section 4, 5, 6, 9.

Control Signal Connector P1-pins

Signal	Functions
PUL+ (+5V)	Pulse signal: in single pulse(pulse/direction) mode, this input represents pulse signal, effective for each upward – rising edge; in double pulse mode (pulse/pulse) this input represents clockwise(CW)pulse. For reliable response, pulse width should be longer than $1.5\mu\text{s}$.
PUL- (PUL)	
DIR+ (+5V)	Direction signal: in single-pulse mode, this signal has low/high voltage levels, representing two directions of motor rotation; in double-pulse mode (set by inside jumper JMP1), this signal is counter-clock (CCW) pulse, effective on each rising edge. For reliable motion response, direction signal should be sent to driver $2\mu\text{s}$ before the first pulse in the reverse motion direction.
DIR- (DIR)	
ENA+ (+5V)	Enable signal: this signal is used for enable/disable, high level for enabling driver and low level for disabling driver. Usually left unconnected(enabled).
ENA- (ENA)	
READY+	Output alarm signal positive: READY is a photocouper output from open-collector circuit, effectively output when driver operate normally, maximum permitted input voltage 30VDC; maximum output current 20mA, generally can be serial connected to PLC input terminal.
READY-	Output alarm signal negative.

Remark 1: SW5 ON means PUL/DIR mode, OFF means CW/CCW (pulse/pulse) mode.

Remark 2: Please note motion direction is also related to motor-driver wiring match. Exchanging the connection of two wires for a coil to the driver will reverse motion direction. (for example, reconnecting motor A+ to driver A- and motor A- to driver A+ will invert motion direction).

Power connector P2 pins

Signal	Functions
AC	AC input, varies from 80V to 220V, recommended to use 180V.
AC	
Phase A	Motor coil A (leads A+ and A-)
Phase B	Motor coil B (leads B+ and B-)
PE	Connect ground terminal

4. Control Signal Connector (P1) Interface

This driver uses differential inputs to increase noise immunity and interface flexibility. Single-ended control signals from the indexer/controller can also be accepted by this interface. The input circuit has built-in high-speed opto-coupler, and can accept signals in the format of line driver, open-collector, or PNP output. Line driver (differential) signals are suggested for reliability. In the following figures, connections to open-collector and PNP signals are illustrated.

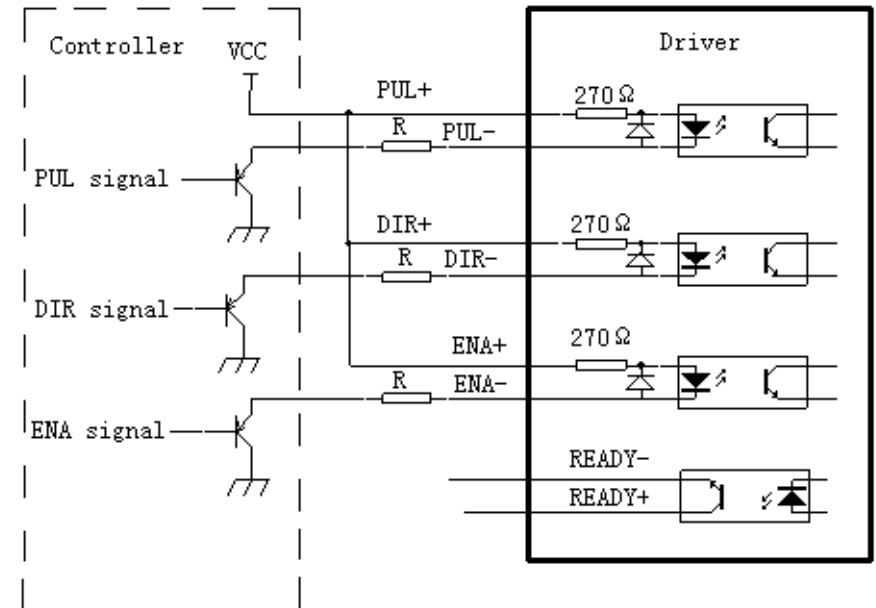

5. Driver Connection to Step Motors

25078 driver can drive any 4, 6, 8 lead hybrid step motors. The following diagrams illustrate connection to various kinds of motor leads:

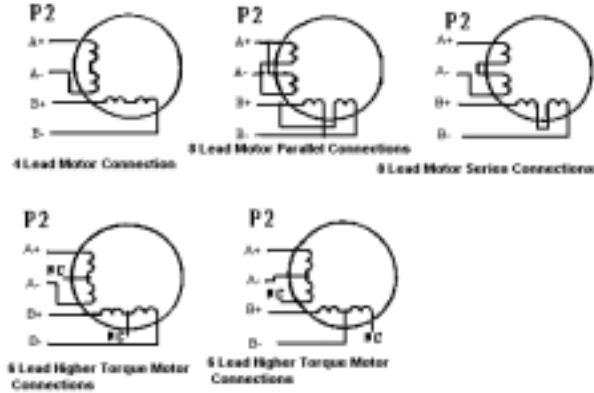

Figure 3: Driver Connection to Step Motor

Note that when two coils are parallelly connected, coil inductance is reduced by half and motor speed can be significantly increased. Serial connection will lead to increased inductance and thus the motor can be run well only at lower speeds.

5.1 Connecting to 8-Lead Motors

8 lead motors offer a high degree of flexibility to the system designer in that they may be connected in series or parallel, thus satisfying a wide range of applications.

Series Connection

A series motor configuration would typically be used in applications where a higher torque at lower speeds is required. Because this configuration has the most inductance, the performance will start to degrade at higher speeds. Use the per phase (or unipolar) current rating as the peak output current, or multiply the bipolar current rating by 1.4 to determine the peak output current.

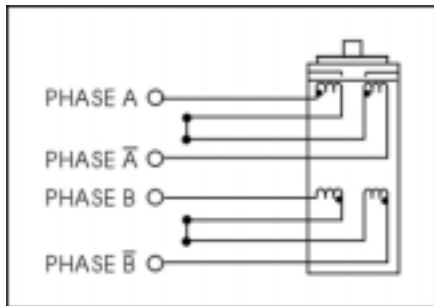

Figure 4: 8 Lead Motor Series Connections

Parallel Connection

An 8 lead motor in a parallel configuration offers a more stable, but lower torque at lower speeds. But because of the lower inductance, there will be higher torque at higher speeds. Multiply the per phase (or unipolar) current rating by 1.96, or the bipolar current rating by 1.4, to determine the peak output current.

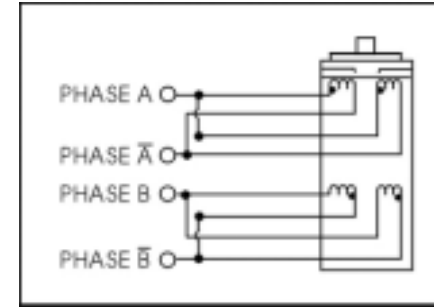

Figure 5: 8 Lead Motor Parallel Connections

5.2 Connection to 6-Lead Motors

Like 8 lead stepping motors, 6 lead motors have two configurations available for high speed or high torque operation. The higher speed configuration, or half coil, is so described because it uses one half of the motor's inductor windings. The higher torque configuration, or full coil, use the full windings of the phases.

Half Coil Configuration

As previously stated, the half coil configuration uses 50% of the motor phase windings. This gives lower inductance, hence, lower torque output. Like the parallel connection of 8 lead motor, the torque output will be more stable at higher speeds. This configuration is also referred to as bal copper. In setting the driver output current multiply the specified per phase (or unipolar) current rating by 1.4 to determine the peak output current.

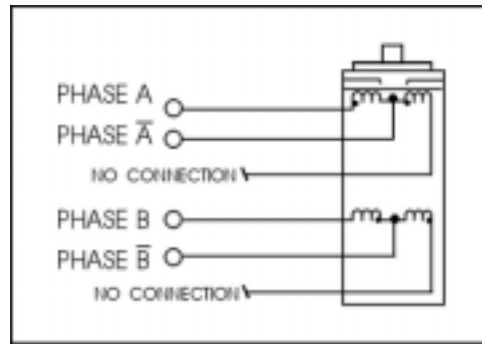

Figure 6: 6 Lead Half Coil (Higher Speed) Motor Connections

Full Coil Configuration

The full coil configuration on a six lead motor should be used in applications where higher torque at lower speeds is desired. This configuration is also referred to as full copper. Use the per phase (or unipolar) current rating as the peak output current.

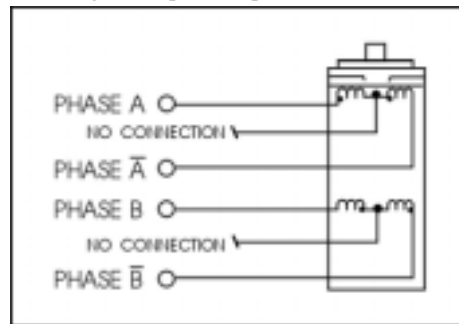

Figure 7: 6 Lead Full Coil (Higher Torque) Motor

5.3 Connection to 4-Lead Motors

4 lead motors are the least flexible but easiest to wire. Speed and torque will depend on winding inductance. In setting the driver output current, multiply the specified phase current by 1.4 to determine the peak output current.

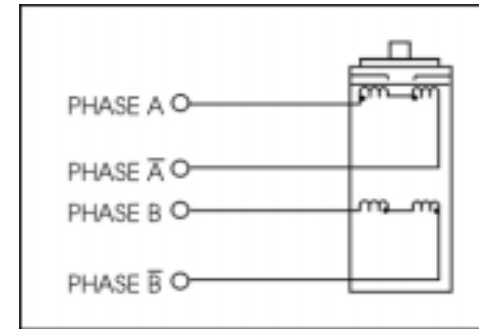

Figure 8: 4 Lead Motor Connections

6. Power supply Selection, Driver Voltage and Current Selection

6.1 Power Supply Selection

It is important to choose appropriate power supply to make the driver operate properly and deliver optimal performance.

Maximum Voltage Input:

The power MOSFETS inside the driver can actually operate within +80 - +220VAC, including power input fluctuation and back EMF voltage generated by motor coils during motor shaft deceleration. Higher voltage will damage the driver. Therefore, it is suggested to use power supplies with theoretical output voltage of no more than +220V, leaving room for power line fluctuation and Back EMF.

Regulated or Unregulated power supply:

Both regulated and unregulated power supplies can be used to supply DC power to the driver. However, unregulated power supplies are preferred due to their ability to withstand current surge. If regulated power supply (such as most switching supplies.) is indeed used, it is important to have large current output rating to avoid problems like current clamp, for example using 4A supply for 3A motor-driver operation. On the other hand, if unregulated supply is used, one may use a power supply of lower current rating than that of motor (typically 50% ~ 70% of motor current). The reason is that the driver draws current from the power supply capacitor of the unregulated supply only during the ON duration of the PWM cycle, but not during OFF duration. Therefore, the average current withdrawn from power supply is considerably less than motor current. For example, two 3A motors can be well supplied by one power supply of 4A rating.

Multiple drivers:

It is recommended to have multiple drivers to share one power supply to reduce cost, provided that the supply has enough capacity. To avoid cross interference, **DO NOT** daisy-chain the power supply input pin of the drivers. (instead, please connect them to power supply separately.)

Higher supply voltage will allow higher motor speed to be achieved, at the price of more noise and heating. If the motion speed requirement is low, it's better to use lower supply voltage to improve noise, heating and reliability.

NEVER connect power and ground in the wrong direction, as it will damage the driver.

6.2 Driver Voltage and Current Selection

This driver can match small and medium size step motors (NEMA 43 and 51), it is important to select supply voltage and output current properly. Generally, supply voltage determines the high speed performance of the motor, while output current determines the output torque of the driven motor (particularly at lower speed).

Selecting Supply Voltage:

Higher supply voltage can increase motor torque at higher speeds, thus helpful for avoiding losing steps. However, higher voltage may cause more motor vibration at lower speed, and it may also cause over-voltage protection and even driver damage. Therefore, it is suggested to choose only sufficiently high supply voltage for intended applications.

Setting Proper Output Current

- For a given motor, higher driver current will make the motor to output more torque, but at the same time causes more heating in the motor and driver. Therefore, output current is generally set to be such that the motor will not overheat for long time operation.
- Since parallel and serial connections of motor coils will significantly change resulting inductance and resistance, it is therefore important to set driver output current depending on motor phase current, motor leads and connection methods.
- Phase current rating supplied by motor manufacturer is important to selecting driver current, but the selection also depends on leads and connection.

7. Selecting Microstep Resolution and Driver Current Output

This driver uses a 9-bit DIP switch to set microstep resolution, motor operating current and pulse mode selection, as shown below:

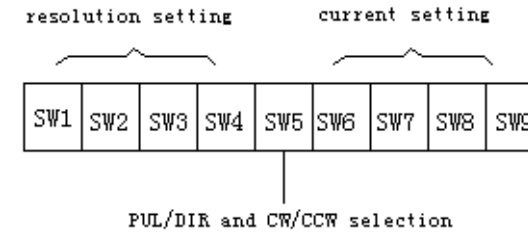
**7.1 Microstep Resolution Selection**

Microstep resolution is set by SW1-SW4 of the DIP switch as shown in the following table:

ustep/rev.(for 1.8 ° motor)	SW1	SW2	SW3	SW4
400	ON	ON	ON	ON
500	OFF	ON	ON	ON
600	ON	OFF	ON	ON
800	OFF	OFF	ON	ON
1000	ON	ON	OFF	ON
1200	OFF	ON	OFF	ON
1600	ON	OFF	OFF	ON
2000	OFF	OFF	OFF	ON
2400	ON	ON	ON	OFF
3200	OFF	ON	ON	OFF
4000	ON	OFF	ON	OFF
5000	OFF	OFF	ON	OFF
6000	ON	ON	OFF	OFF
6400	OFF	ON	OFF	OFF
8000	ON	OFF	OFF	OFF
10000	OFF	OFF	OFF	OFF

7.2 Current Setting

The SW6-SW9 of the DIP switch are used to set the current during motion (dynamic current). Select a setting closest to your motor's required current.

- **DIP Setting for current during motion:**

25078		DIP switch setting			
Peak current (A)	RMS (A)	SW6	SW7	SW8	SW9
0.45	0.32	OFF	OFF	OFF	OFF
0.63	0.45	OFF	OFF	OFF	ON
1.41	1.00	OFF	OFF	ON	OFF
1.88	1.34	OFF	OFF	ON	ON
2.33	1.66	OFF	ON	OFF	OFF
2.85	2.04	OFF	ON	OFF	ON
3.23	2.31	OFF	ON	ON	OFF
3.75	2.68	OFF	ON	ON	ON
4.26	3.04	ON	OFF	OFF	OFF
4.65	3.32	ON	OFF	OFF	ON
5.18	3.70	ON	OFF	ON	OFF
5.55	3.96	ON	OFF	ON	ON
6.15	4.39	ON	ON	OFF	OFF
6.60	4.71	ON	ON	OFF	ON
7.20	5.14	ON	ON	ON	OFF
7.80	5.57	ON	ON	ON	ON

Remarks:

Due to motor inductance the actual current in the coil may be smaller than the dynamic current settings, particularly at higher speeds.

- **Static current**

The current automatically reduced to 60% of dynamic current setting 0.2 second after the last pulse, this will, theoretically, reduce motor heating to 36% (due to I^2R) of the original value.

- **DIP setting for pulse mode:**

SW5 is used for this purpose. ON means CW/CCW mode, OFF means PUL/DIR mode.

8. Protection Functions

Over-voltage, short-voltage, over-current, over-heating and short-circuit protection

To improve reliability, the driver incorporates a number of built-in protection features.

a. Over-voltage protection and short-voltage protection

When power supply voltage exceeds +250VAC, protection will be activated and power indicator LED will turn red. When power supply voltage is lower than +80VAC, the driver will not work properly.

b. Coil-ground Short Circuit Protection

Protection will be activated in case of short circuit between motor coil and ground.

c. Over-current Protection

Protection will be activated in case of short current which may otherwise damage the driver.

Attention: since there is no protection against power leads (+, -) reversal, it is critical to make sure that power supply leads are correctly connected to driver. Otherwise, the driver will be damaged instantly.

9. Connection Diagram for Driver, Motor, Controller

A complete stepping system should include stepping motor, stepping driver, power supply and controller (pulse generator).

A typical connection is shown below:

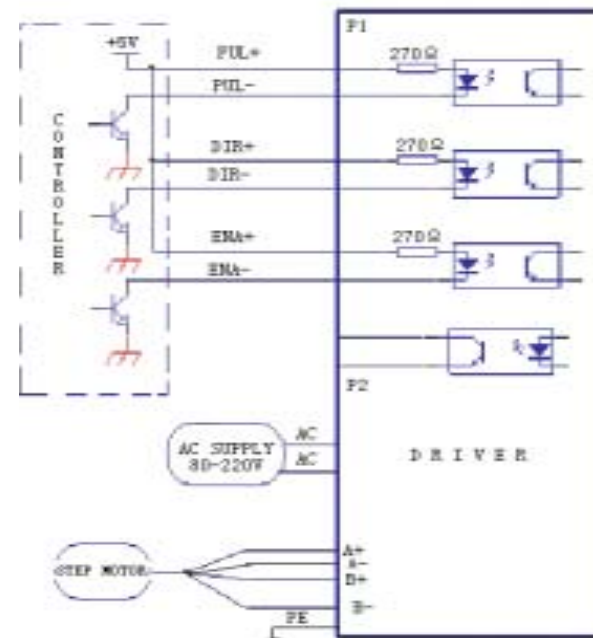
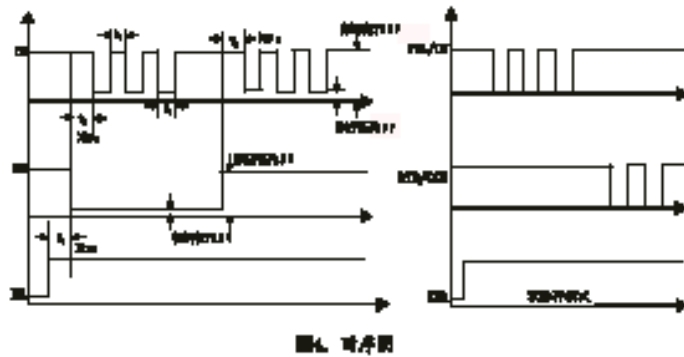

Figure 9: Driver connection in a stepping system

10. Control signal Waveform and Timing

In order to avoid some fault operation and deviation, PUL, DIR and ENA must accord with some parameters, as following diagram:

**Remark:**

- (1) t1: ENA+ must be ahead of DIR by at least 5 μ s, logic HIGH as valid. Generally ENA+ and ENA- is NC (not connected).
- (2) t2: DIR must be ahead of PUL effective falling edge by 5 μ s to ensure correct direction;
- (3) t3: Pulse width not less than 1.2 μ s;
- (4) t4: low level width not less than 1.2 μ s.

11. Wire Connection

- (1) In order to improve driver noise rejection, it is recommended to use twisted pair shield cable.
- (2) To prevent noise incurred in pulse/dir signal, Pulse/direction signal wires and motor wires should not be tied up together. It is better to separate them by at least 10 cm, otherwise the motor noise will easily disturb pulse direction signals, motor position error, system instability and other types of failure.
- (3) If a power supply serves several drivers, separate connections drivers is recommended instead of daisy-chaining.
- (4) It is prohibited to pull and plug connector P2 while driver is powered ON, as there is still high current flowing through coil even when motor is stopped. Pulling and plugging P2 with power on will cause extremely high voltage surge EMF, destroy the driver.